

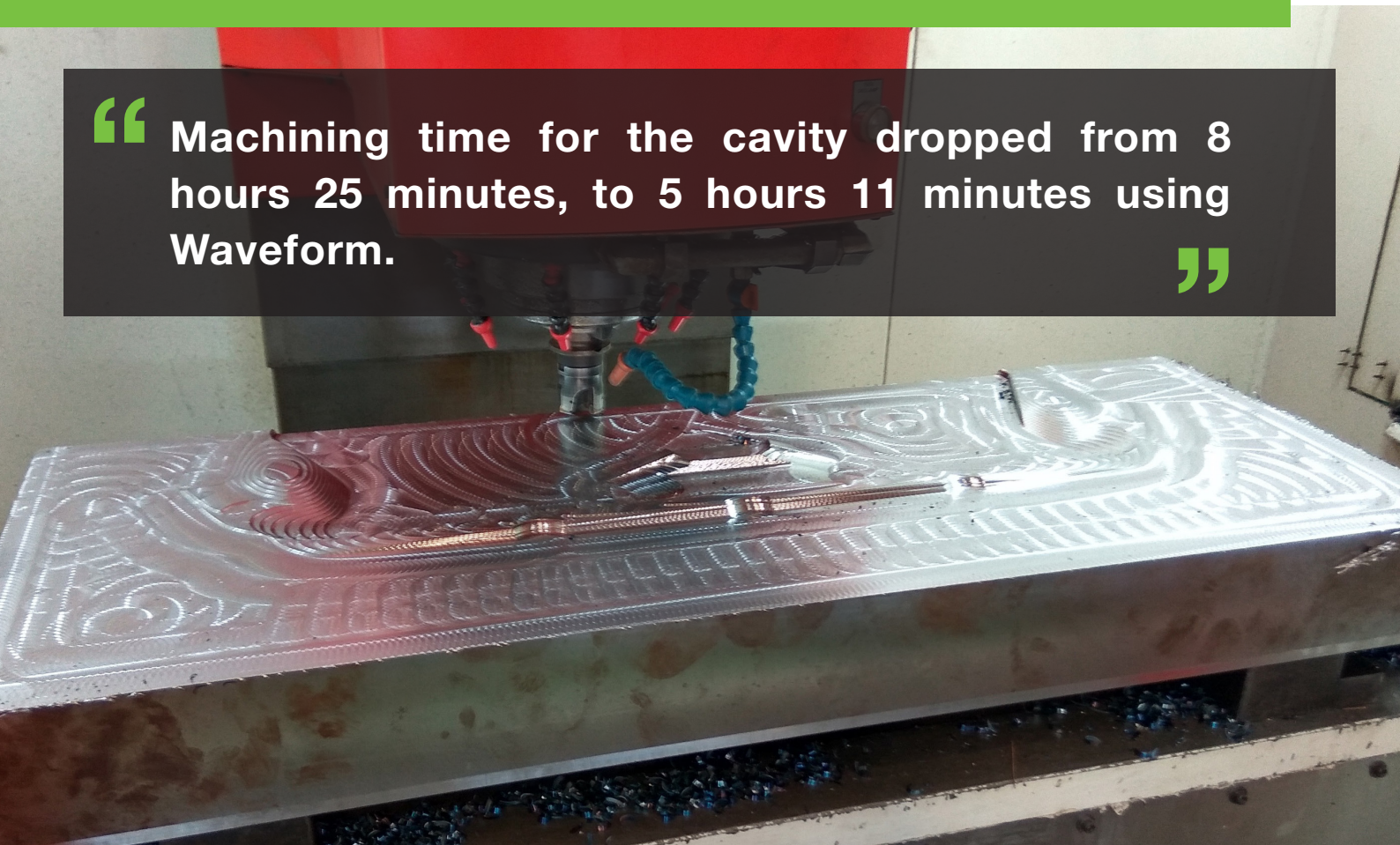

M-TEK ENGINEERS

“ Machining time for the cavity dropped from 8 hours 25 minutes, to 5 hours 11 minutes using Waveform. ”



WorkNC CAM software is the premier automatic CNC software for surface or solid models in mold, die and tooling businesses for 2 to 5-axis CNC programming. WorkNC is used by all western, Japanese and Korean automotive makers and well-known OEMs from a range of other industries.

WorkNC is best of breed, complementary CAM software that enhances all design and manufacturing systems by providing the most reliable, efficient, easy-to-program cutter paths, resulting in unmatched productivity and safety.

M-TEK Engineers

WorkNC Waveform Slashes Machining Time And Increases Tool Life

The revolutionary Waveform Roughing Strategy from Vero Software has reduced machining times by 40 per cent for a manufacturer of vehicle guards, roof racks and steps, while tripling cutting tool life.

M-TEK Engineers, based at Pune, in India, were having issues with machining automotive accessory parts on a 3-axis BFW vertical mill, with power of only 7.5kv on the BT40 spindle.

M-TEK Director Mandar Kirane says: "This meant we weren't able to use a 52 R 3 bull nose Hitachi cutter with more than a 0.5 mm depth of cut. If we did, the load increased on the spindle, causing the machine to stop.

However, after updating their WorkNC software to the new 2017 R1 release which incorporates Waveform Roughing, the new programs utilised a 1.2 mm depth of cut with the same tool, and ran successfully on the machine, giving a constant spindle load.

CNC programmer Sachine Maindargikar says the WorkNC Waveform programs increased the cutter life threefold, and cut machining time by 40 per cent.

"One part – the core for an SUV front bumper guard – took 10 hours 14 minutes to machine using traditional methods, but just six hours 38 minutes with Waveform. And machining time for the cavity dropped from 8 hours 25 minutes, to 5 hours 11 minutes using Waveform."

An ISO 9001:2008 and 14001:2004 certified accessories manufacturer, M-TEK have more than 15 years experience, and a workforce of more than 350, including 15 engineers specialising in production, development, marketing and design.



About The Company:

Name:
M-TEK Engineers

Business:
Manufacturer of vehicle guards, roof racks and steps based at Pune, in India.

Website:
www.mtekengineers.com

Benefits Achieved:

- Reduced machining times by 40 per cent
- Tripled the cutting tool life.
- Constant spindle load

Comments:

"We've conducted the trials and discovered that the new Waveform roughing strategy in WorkNC can save our machining time up to 40 per cent, compared to regular methods."

Sachine Maindargikar
CNC Programmer
M-TEK Engineers

Their products include:

- A market leading range of front guards for a variety of cars which improve the appearance and protects the front bumper. They are available in a choice of materials, including Stainless Steel, ABS, and Polyurethane. M-TEK are India's only accessories manufacturer with ABS blow moulding and Polyurethane foam injection facilities in one factory, with a vertical machining centre.
- Guards to protect the rear side of the vehicle, particularly useful when parking.
- Roof racks.
- Steps for the doors, making it easier for young children and the elderly to get in and out of the car.

Sachine Maindargikar says WorkNC now plays a vital role in the full manufacturing process: "Beforehand, we used to outsource the jobs for machining. But during our review meeting in October 2016, our management decided to stop outsourcing and find the better ways to increase the productivity, in-house."

"I contacted the WorkNC team and they immediately suggested trails with Waveform. We've conducted the trails and discovered that the new Waveform roughing strategy in WorkNC can save our machining time up to 40 per cent, compared to regular methods."

In total, M-TEK have two vertical machining centres, and five conventional CNC machine tools, including two BFW Chakra BMV 60+ machines, and one BMV 60++.

The company, which is an OEM supplier to vehicle manufacturers Mahindra & Mahindra and Tata Motors Ltd., operates out of a 120,000-square foot factory, and has plans to expand with a further 25,000 square feet.

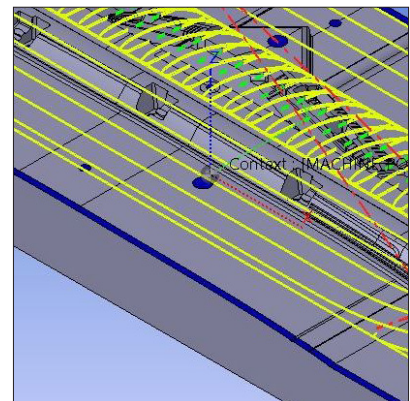
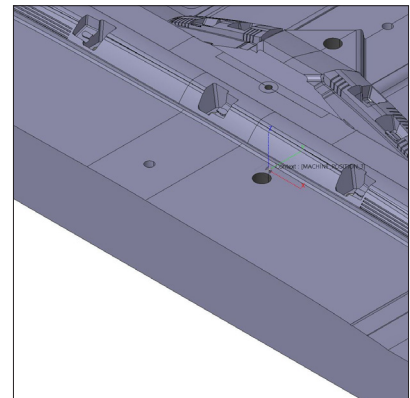
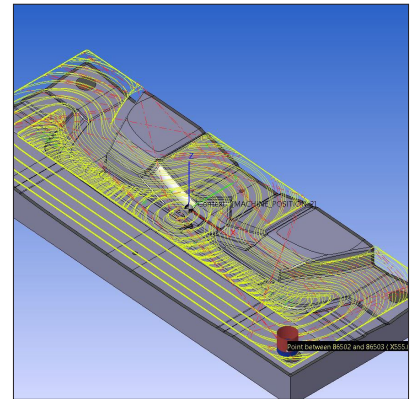
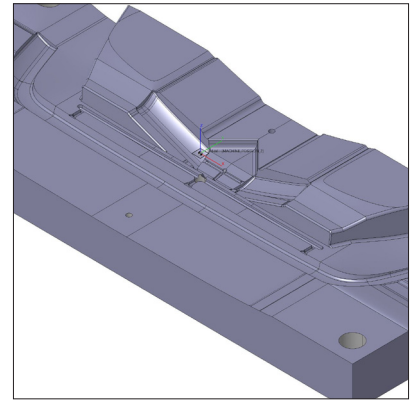

WorkNC中国总代理
上海强互信息科技有限公司
Tel: 021-50304630 Fax: 021-50307213
E-mail: qianghu@qianghu.com
Web: www.qianghu.com
Add: 上海市浦东新区新金桥路1122号
方正大厦1201、1202室



扫一扫二维码
更多WorkNC最新资讯

worknc

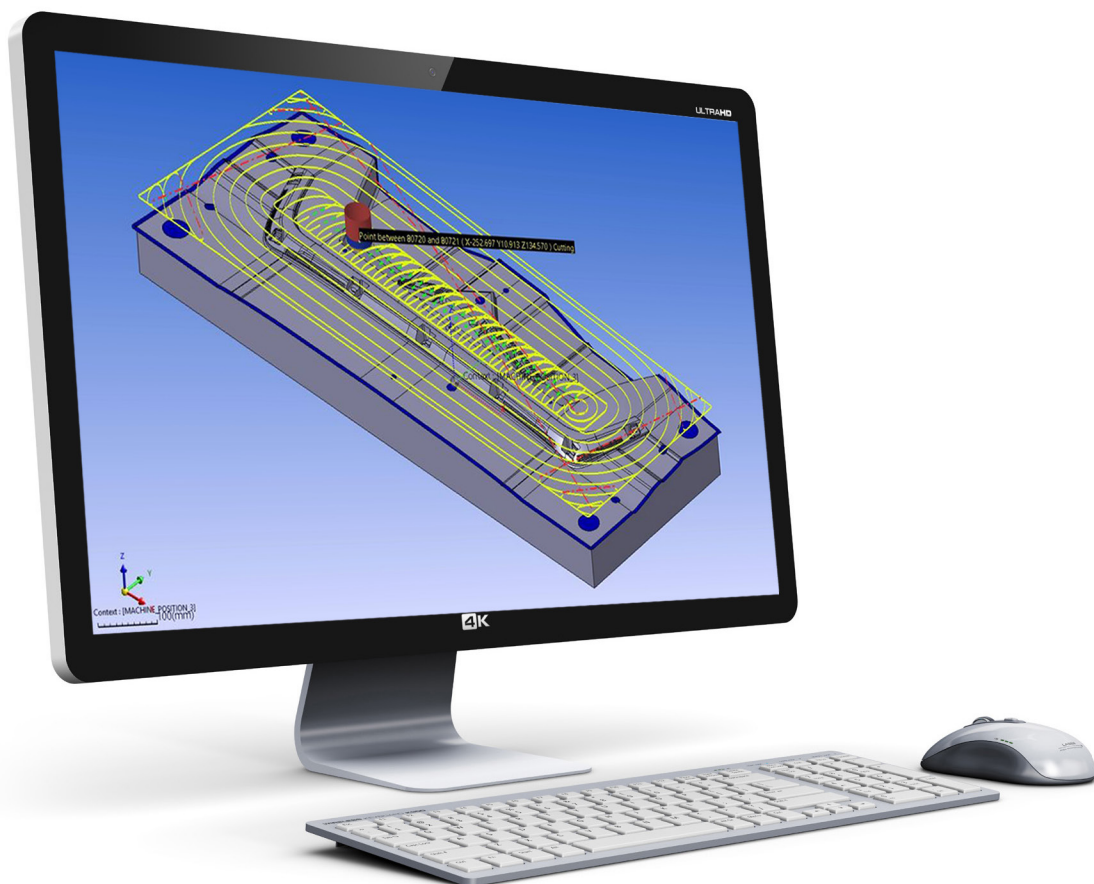

WorkNC China Master Distributor
Shanghai Qianghu Information Technology Co.,Ltd
Tel: 021-50304630 Fax: 021-50307213
Email: qianghu@qianghu.com
www.qianghu.com

vero
Software